

# Gen2 Gears

KSE Racing Products' GEN 2 steering gear was initially released in 2005 and it helped to revolutionize the sprint car steering system with its integral reservoir and in-board mount design. The GEN 2 quickly took the industry by storm to become the industry's leading power steering system.

The GEN 2 is the trusted choice of America's top drivers and premier race teams...Donny Schatz, Steve Kinser, Jason Myers, Joey Saldana, Craig Dollansky, Jerry Coons, Jason Johnson, Greg Hodnett, Bud Keading, Bryan Clauson, and the list goes on-and-on. The results undoubtedly speak for themselves!



## Built-in Reservoir

The reservoir is built into the live hub tube of the gear. This design eliminates turbulence, aeration, and provides the most cooling of any tank KSE has tested. The easy-fill 2" diameter cap is vented and has a built-in dipstick.

## Wing Slider Ports

Standard on all GEN 2 gears, the wing slider ports are o-ring sealed. Special high-flow #3 o-ring boss to 37-degree JIC #4 fittings are available.

## Positive Feel

The new four-degree valve and 20% faster lead ball screw transfers quicker front wheel feedback to the hydraulic assist to improve front wheel stability. The inboard mount improves top steering gear mount rigidity, which reduces the rotation of the gear box in the chassis when steering.

## Consistent Feel

The new four-degree valve contours the pressure load over a greater range than the previous two-degree valve. This provides a more uniform feel in the steering wheel regardless of the steering load on the front wheels.

## Improved Durability

Solid-model design and structural analysis were utilized to design a casting that is considerably stronger. The cross shaft tooth form is 40% stronger. The inboard mount eliminates the steering gear as a structural member of the chassis.

## Less Weight

The GEN 2 is the lightest steering gear currently on the market! It is comparable to the weight of the KSE Pro Lite gear and is 25% lighter than the previous 1st generation KSE gear.



### Simplified Plumbing

A #10 line from the built-in reservoir to the pump inlet, and a #6 pressure line from the pump to the pressure port is all that is needed. The return to the reservoir is internally ported. The GEN 2 eliminates all external tubes and fittings of the standard gear.

### Easier and Cleaner Installation

The inboard mount makes installation and removal quicker and easier. It also improves leg-room and minimizes throttle linkage issues. The built-in reservoir and internal plumbing eliminate hoses, fittings and a remote-mounted reservoir. The built-in wing slide ports eliminate fittings and hoses—further simplifying installation.

### No “Tight” Spots

Tight spots are caused by the steering load being greater than the pressure the pump can deliver. Output torque has been increased by 15% relative to pressure. The inboard mount also eliminates binding of the steering gear due to chassis flex.

### Value

The industry-leading GEN 2 is priced comparable to the previous standard KSE gear with a dead-tube reservoir. All-in-all, the outstanding quality, durability, and the extras add up to an amazing value. Don't be fooled by “warranties”...we pride ourselves on producing the absolute best products at the fairest prices with unmatched service.



## Gen2 Power Steering Gear Plumbing Circuit

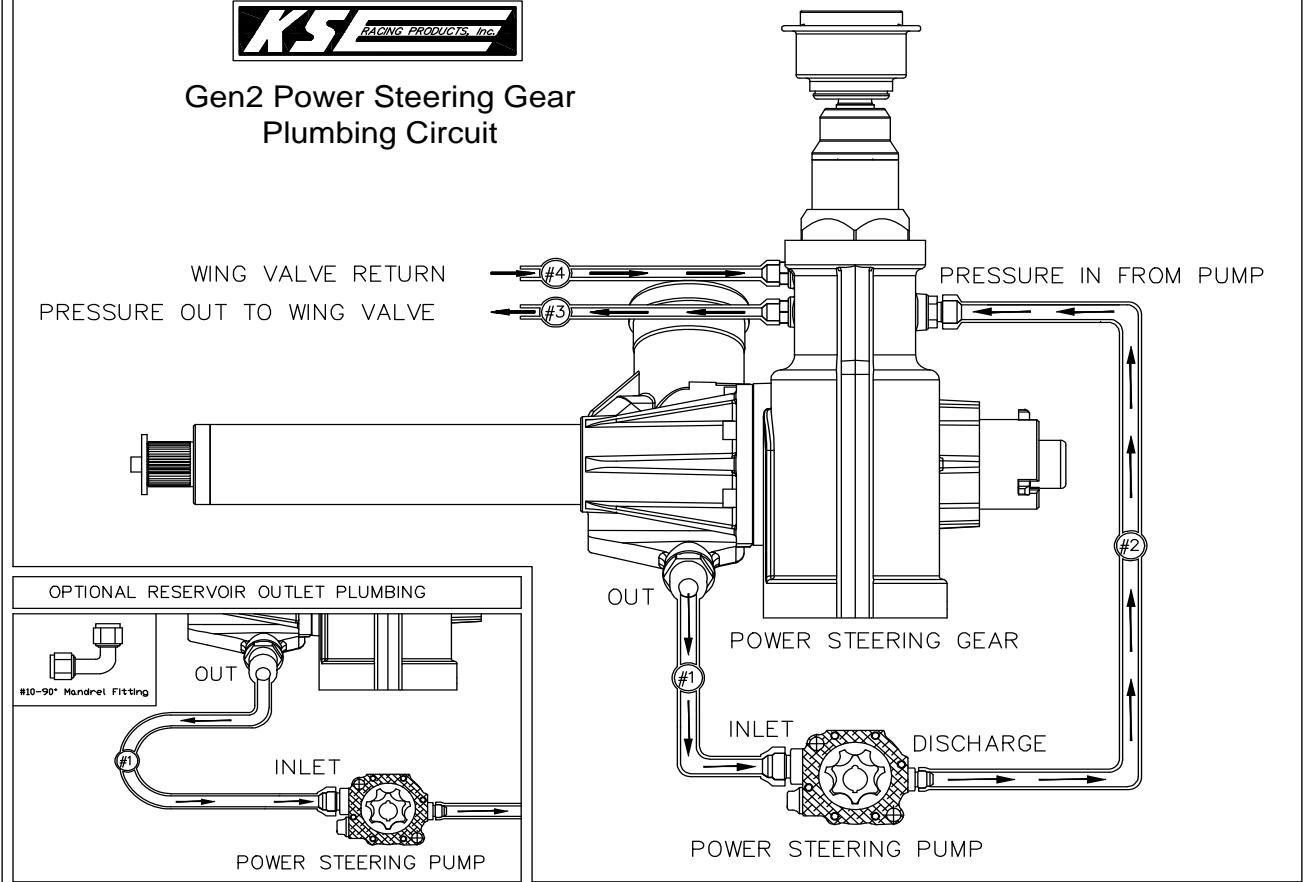

# Gen2 Gears

## How to Order:

Create the part number of the gear you need by selecting the desired options in the boxes below and insert their code number into the part number.

## Example:

**KSGEN2L-3852** is a left-hand gear with 10" input shaft, 18" output shaft, a "35" servo valve, and a pull-type quick release.

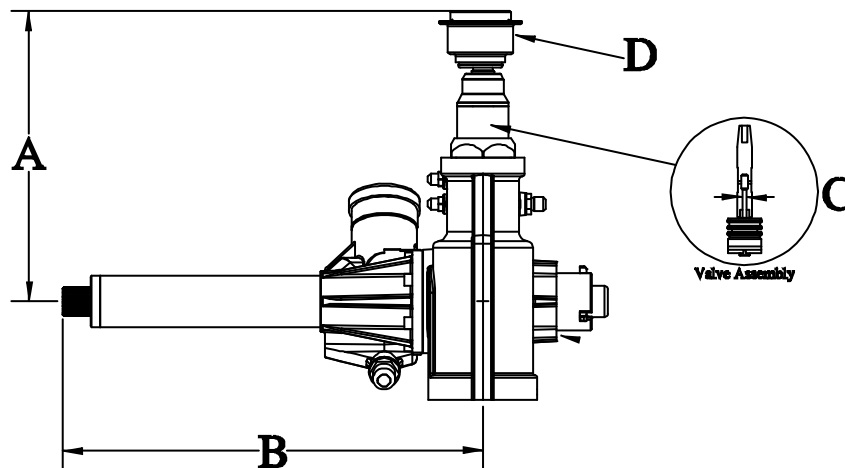

KSGEN2 -

Gear Type Code	"A" Input Shaft Code	"B" Live Tube Output Shaft Code	"C" Servo Valve Effort Code	"D" Steering Wheel Hub Release Code
L = Gen2 Left-Hand Gear	3 = 10" 5 = 11"	4 = 14" 6 = 16" 8 = 18"	4 = "20" (Easy) 5 = "35" 6 = "40" 7 = "50" 8 = "65" (Firm)	0 = No Quick Release 2 = Pull-Type Quick Release

### "A" Input Shaft

- Measurement is made from the steering wheel mounting surface of the quick release hub to the center line of the output shaft.
- Input shaft length is based upon driver preference; 11" is the most common in Sprint and Silver Crown cars. 10" and 11" are also used in Midgets.

### "B" Live Tube Output Shaft

- Dimension is determined by chassis width, as well as the desired location of the drag link.
- 14" and 16" are common left side Midget lengths.
- 16" and 18" are common left side Sprint and Silver Crown lengths. 16" with the wide angle broached pitman arm are used to maximize weight reduction.

### "C" Servo Valve Effort

- The servo valve torsion bar determines the effort required to steer by the driver. This is a driver preference. All KSE gears have the torsion bar size stamped on the web side of the case, next to the serial number.
- A "20" is the least effort size, and a "65" requires the most effort.
- Dirt sprint cars and Silver Crown drivers generally choose the lower efforts (35-40), while Midgets and pavement drivers choose higher efforts (40-50).

### \*\*NEW AND DEVELOPING DRIVERS\*\*

- The GEN 2 is a great steering system for young and developing drivers starting out. We recommend evaluating a steering gear with a shorter input (10") and the smallest servo valve torsion bar ("20"). Please call with any questions!

# Parts & Accessories



**KSG1027**  
Pull-Type Quick Release Hub



**KSG0031**  
Pitman Arm Straight

**KSG0043**  
Pitman Arm Angle Spline



**KSM1053**  
Steering Wheel 15" Flat



**KSM6002**  
#3 ORB to #4 JIC High-Flow Wing Slider Fitting for Gen2 Gear



Steering Gear Seal Kit  
**KSG0032** (First Gen Gear)  
**KSG0035** (Gen2 Gear)



NEW!

**KSG1070**  
Lightweight Billet Aluminum Inboard Mounting Bracket



**KSG1071**  
Weld-In Mounting Tabs for KSG1070

**CONVERT YOUR FIRST GENERATION KSE STEERING GEARS TO A CENTER MOUNT... PERFECT FOR MAKING AN INTERCHANGEABLE BACKUP UNIT!**



**KSG0010**  
Center Mount Hub Aluminum (First Gen Gear Only)

**KSG0010M**  
Center Mount Hub Magnesium (First Gen Gear Only)



Live Tube Reservoir  
(First Gen Gear Only, Specify 14", 16", or 18" length when ordering)

Aluminum  
**KSF1044-014**  
**KSF1044-016**  
**KSF1044-018**  
**KSF1044-018R** (Right Side Gear)

Magnesium  
**KSF1044M-14**  
**KSF1044M-16**  
**KSF1044M-18**



Dead Tube Reservoir  
(First Gen Gear Only, Specify 6.25", 7.25", or 8.75" length when ordering)

Aluminum  
**KSF1035-625**  
**KSF1035-725**  
**KSF1035-875**

Magnesium  
**KSF1035-625M**  
**KSF1035-725M**  
**KSF1035-875M**

STEERING GEARS

TANDEM PUMPS

PULLEYS & DRIVE KITS

POWER STEERING PUMPS

WATER PUMPS & FRONT COVERS

FLUIDS & ACCESSORIES

SERVICES

TECHNICAL INFO